

IQ SENSOR NET MIQ/C6

IQ SENSOR NET SIX-CHANNEL CURRENT OUTPUT MODULE



a xylem brand

Copyright © 2018 Xylem Analytics Germany GmbH
Printed in Germany.

MIQ/C6 - List of contents

1	Overview	5
1.1	How to use this component operating manual	5
1.2	Features of the MIQ/C6	6
2	Safety instructions	7
2.1	Safety information	7
2.1.1	Safety information in the operating manual	7
2.1.2	Safety signs on the product	7
2.1.3	Further documents providing safety information	7
2.2	Safe operation	8
2.2.1	Authorized use	8
2.2.2	Requirements for safe operation	8
2.2.3	Unauthorized use	8
2.3	User qualification	8
3	Installation	9
3.1	Scope of delivery	9
3.2	Installation in the IQ SENSOR NET	9
3.3	Electrical connections: General instructions	9
3.4	Connections to the current outputs	10
4	Settings	12
5	Maintenance and cleaning	13
5.1	Maintenance	13
5.2	Cleaning	13
6	Technical data	14
6.1	General data	14
6.2	MIQ/C6	16
7	Lists	18
7.1	Explanation of the messages	18
7.1.1	Error messages	18
7.1.2	Informative messages	18

1 Overview

1.1 How to use this component operating manual

Structure of the IQ SENSOR NET operating manual

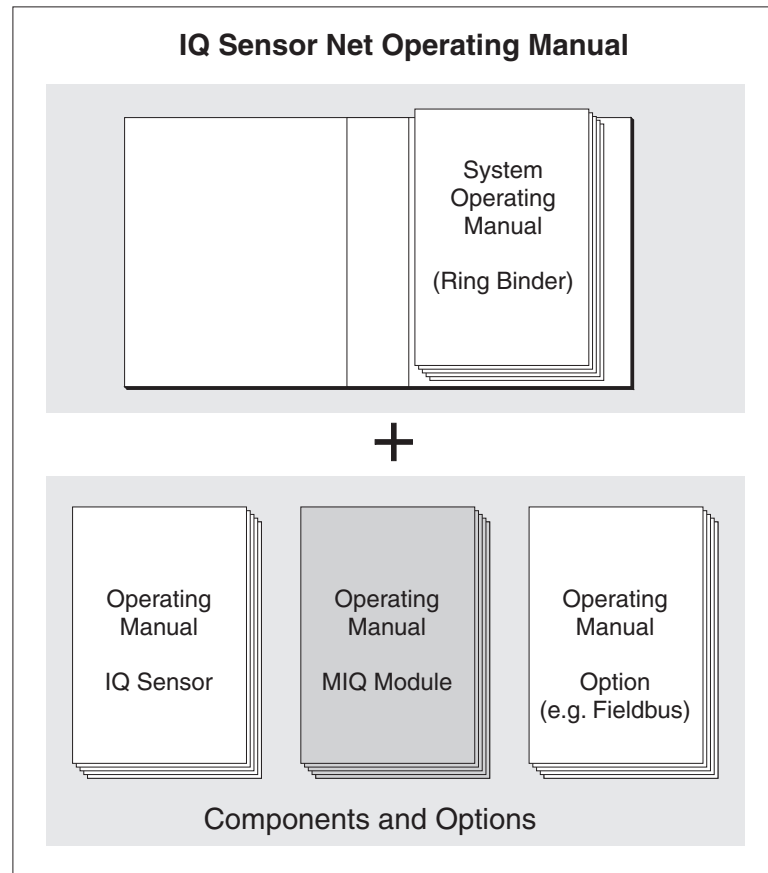

Fig. 1-1 Structure of the IQ SENSOR NET operating manual

The IQ SENSOR NET operating manual has a modular structure like the IQ SENSOR NET itself. It consists of a system operating manual and the operating manuals of all the components used.

Please file this component operating manual into the ring binder of the system operating manual.

1.2 Features of the MIQ/C6

General characteristics

The MIQ/C6 output module has six current outputs. They can be programmed as:

- Analog output (recorder)
- PID regulator

You can link current outputs to sensors. The linked current outputs can be used to monitor sensors or for control purposes.

With the standard MIQ module housing, the MIQ/C6 has the same characteristics as all MIQ modules regarding stability, leakproofness and weather resistance. It also provides the same wide variety of installation options (stacked mounting, canopy mounting, tophat rail mounting, etc.).

Terminal strip

The MIQ/C6 has the following electrical connections on the terminal strip inside the housing:

- 6 x current output
- 2 x SENSORNET connection

2 Safety instructions

2.1 Safety information

2.1.1 Safety information in the operating manual

This operating manual provides important information on the safe operation of the product. Read this operating manual thoroughly and make yourself familiar with the product before putting it into operation or working with it. The operating manual must be kept in the vicinity of the product so you can always find the information you need.

Important safety instructions are highlighted in this operating manual. They are indicated by the warning symbol (triangle) in the left column. The signal word (e.g. "CAUTION") indicates the level of danger:

**WARNING**

indicates a possibly dangerous situation that can lead to serious (irreversible) injury or death if the safety instruction is not followed.

**CAUTION**

indicates a possibly dangerous situation that can lead to slight (reversible) injury if the safety instruction is not followed.

NOTE

indicates a situation where goods might be damaged if the actions mentioned are not taken.

2.1.2 Safety signs on the product

Note all labels, information signs and safety symbols on the product. A warning symbol (triangle) without text refers to safety information in this operating manual.

2.1.3 Further documents providing safety information

The following documents provide additional information, which you should observe for your safety when working with the measuring system:

- Operating manuals of other components of the IQ SENSOR NET system (power supply modules, controller, accessories)
- Safety datasheets of calibration and maintenance equipment (e.g. cleaning solutions).

2.2 Safe operation

2.2.1 Authorized use

The authorized use of the MIQ/C6 consists of providing current outputs in the IQ SENSOR NET. Only the operation according to the instructions and technical specifications given in this operating manual is authorized (see chapter 6 TECHNICAL DATA). Any other use is considered unauthorized.

2.2.2 Requirements for safe operation

Note the following points for safe operation:

- The product may only be operated according to the authorized use specified above.
- The product may only be operated under the environmental conditions mentioned in this operating manual.
- The product may only be supplied with power by the energy sources mentioned in this operating manual.
- The product may only be opened if this is explicitly described in this operating manual (example: connecting electrical lines to the terminal strip).

2.2.3 Unauthorized use

The product must not be put into operation if:

- it is visibly damaged (e.g. after being transported)
- it was stored under adverse conditions for a lengthy period of time (storing conditions, see chapter 6 TECHNICAL DATA).

2.3 User qualification

Target group	The IQ SENSOR NET system was developed for online analysis. Some maintenance activities, e.g. changing the membrane caps in D.O. sensors, require the safe handling of chemicals. Thus, we assume that the maintenance personnel is familiar with the necessary precautions to take when dealing with chemicals as a result of their professional training and experience.
Special user qualifications	The following installation activities may only be performed by a qualified electrician: <ul style="list-style-type: none">● Connection of the MIQ/C6 to the power supply.● Connection of external, line voltage-carrying circuits to relay contacts (see module manual of the relay output module).

3 Installation

3.1 Scope of delivery

- MIQ module
- Accessory set, including:
 - 4 x cable glands (clamping range 4.5-10 mm) with seals and blind plugs
 - 4 x ISO blind nuts M4 with suitable cheese-head screws and plain washers
 - 2 x countersunk screws M3x6 to close the module lid (+ 2 replacement screws)
 - 1 x contact base with fixing screws
- Accessory kit, including
 - 1 x extension M16x1.5 to M20x1.5 with O-ring
 - 1 x cable gland
- Operating manual.

3.2 Installation in the IQ SENSOR NET

The IQ SENSOR NET provides a number of options for integrating the MIQ/C6 mechanically and electrically in the system (stacked mounting, distributed mounting, etc.). The various types of installation are described in detail in the INSTALLATION chapter of the system operating manual.

3.3 Electrical connections: General instructions

Cable glands

All electric cables are fed from below via prepared openings in the enclosure of the MIQ/C6. Cable glands with different clamping ranges are included with the MIQ/C6 to provide sealing between the cable and enclosure as well as for strain relief. Select the matching cable gland for the respective cable diameter:

- **Small**, clamping range 4.5 to 10 mm. This cable gland is suitable for all IQ SENSOR NET sensor cables.

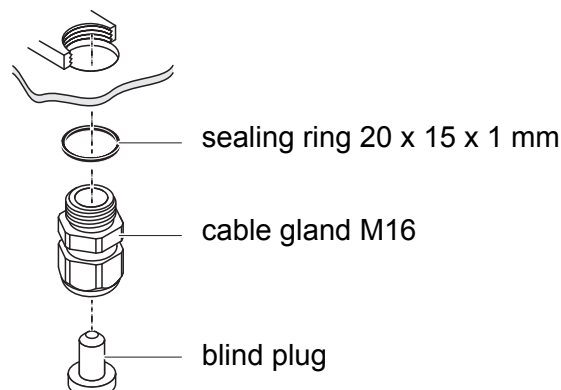

- **Large**, clamping range 7 to 13 mm. This cable gland is required for cable sheaths with an outside diameter of more than 10 mm and is screwed into the enclosure via an extension piece.

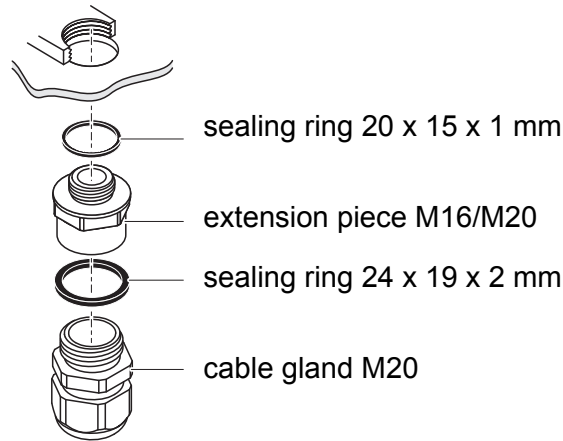

If necessary, you can order more large cable glands in a set of 4 pieces (Model EW/1, Order No. 480 051).

General installation instructions

Observe the following points when attaching connecting wires to the terminal strip

- Shorten all wires to be used to the length required for the installation
- Always fit all the ends of the wires with wire end sleeves before connecting them to the terminal strip
- Any wires that are not used and project into the enclosure must be cut off as closely as possible to the cable gland.
- Screw a small cable gland with sealing ring into each remaining free opening and close it with a blind plug.

3.4 Connections to the current outputs

Materials required

- Wire end sleeves, suitable for the connecting wires, with suitable crimping tool
- 4 x cable gland with sealing ring (scope of delivery MIQ/C6)

Tools

- Cable stripping knife
- Wire stripper
- Phillips screw driver
- Small screw driver

4 Settings

The MIQ/C6 module has six current outputs that supply a current that depends on the measured value.

On the IQ SENSOR NET terminal, you can

- assign names to the outputs.
- link outputs with sensors
- delete links of outputs with sensors
- adjust outputs
- check the condition of the outputs

Functions of current outputs

Current output

- *Recorder*
- *PID controller*
- *Fixed current value*



The following informations are given in the system operating manual for your IQ SENSOR NET system:

- general operating principles
- settings for the outputs

5 Maintenance and cleaning

5.1 Maintenance

The MIQ/C6 requires no special maintenance. The general maintenance of IQ SENSOR NET components is described in the IQ SENSOR NET system operating manual.

5.2 Cleaning

The cleaning of IQ SENSOR NET components is described in the IQ SENSOR NET system operating manual.

6 Technical data

6.1 General data

Dimensions

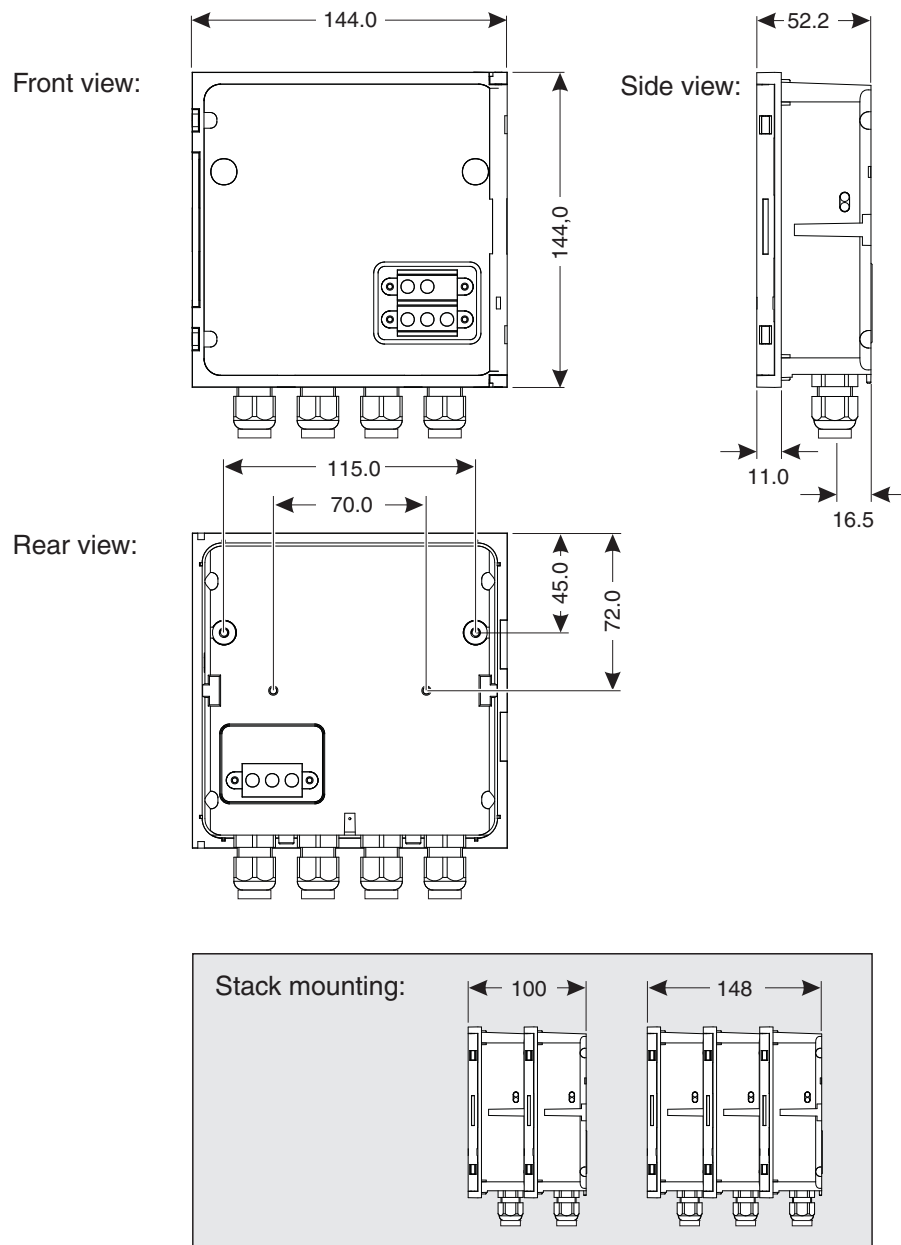

Fig. 6-1 Dimension drawing of MIQ module (dimensions in mm)

Mechanical structure

Maximum number of MIQ modules in a module stack

3

Enclosure material

Polycarbonate with 20 % glass fiber

	Weight	Approx. 0.5 kg
	Type of protection	IP 66 (not suitable for conduit connection).
Cable glands	Suitable for cable sheath diameter	4.5 - 10 mm or 9.0 - 13 mm
Ambient conditions	Temperature	
	Mounting/installation/maintenance	+ 5 °C ... + 40 °C (+ 41 ... +104 °F)
	Operation	- 20 °C ... + 55 °C (- 4 ... + 131 °F)
	Storage	- 25 °C ... + 65 °C (- 13 ... + 149 °F)
	Relative humidity	
	Mounting/installation/maintenance	≤ 80 %
	Yearly average	≤ 90 %
	Dew formation	Possible
	Site altitude	Max. 2000 m above sea level
Meter safety	Applicable norms	<ul style="list-style-type: none"> - EN 61010-1 - UL 61010-1 - CAN/CSA C22.2#61010-1
EMC product and system characteristics	EN 61326	<p>EMC requirements for electrical resources for control technology and laboratory use</p> <ul style="list-style-type: none"> - Resources for industrial areas, intended for indispensable operation - Interference emission limits for resources of class A
	System lightning protection	Noticeably extended qualitative and quantitative protective characteristics as opposed to EN 61326
	FCC, class A	

6.2 MIQ/C6

Electrical data	Nominal voltage	Max. 24 VDC via the IQ SENSOR NET (for details, see the TECHNICAL DATA chapter of the IQ SENSOR NET system operating manual)
	Power consumption	3 W
	Protective class	II
	Overvoltage category	II
Terminal connections	IQ SENSOR NET connections	2 Additional connectable SENSORNET terminator (terminating resistor)
	Number of current outputs	6
	Terminal type	Screw-type terminal strip, accessible by opening the lid
	Terminal ranges	Solid wires: 0.2 ... 4.0 mm ² AWG 24 ... 12 Flexible wires: 0.2 ... 2.5 mm ²
	Line cross-section of cables carrying mains voltage	Europe: 1.5 ... 4.0 mm ² USA: AWG 14 ... 12
	Cable feeds	4 cable glands M16 x 1.5 on the underside of the module
Current outputs	Output	Physically separated from the IQ SENSOR NET
	Output current	Can be switched between 0 - 20 mA and 4 - 20 mA In the case of errors, can be set to: 0 ... 21 mA
	Max. initial output voltage	15 V, in the case of missing or incorrect burden
	Max. load	500 Ω
	Accuracy	0.3 % ± 50 μA

Functions

Programmable as:

- Analog output (recorder)
- PID regulator
- Output with fixed current value (for test purposes)

7 Lists

7.1 Explanation of the messages

In this chapter you will find a list with all the message codes and corresponding message texts that may occur in the log book of the IQ SENSOR NET system for the MIQ/C6 output module.



Information about

- Contents and structure of the log book and
- Structure of the message code

can be found in the LOG BOOK chapter of the IQ SENSOR NET system operating manual.



All message codes of the MIQ/C6 output module end with the number, "421".

7.1.1 Error messages

Message code	Message text
EA4421	<i>Current output range undercut</i> * <i>Check process</i> * <i>Check settings and, if necessary, change them</i>
EA5421	<i>Current output range exceeded</i> * <i>Check process</i> * <i>Check settings and, if necessary, change them</i>
EI3421	<i>Burden resistor too large (> 500 Ohm)</i> <i>or current loop interrupted</i> * <i>Check burden, terminal connections and connection lines</i>

7.1.2 Informative messages

The MIQ/C6 output module does not send informative messages.

Xylem |'zīləm|

- 1) The tissue in plants that brings water upward from the roots;
- 2) a leading global water technology company.

We're a global team unified in a common purpose: creating advanced technology solutions to the world's water challenges. Developing new technologies that will improve the way water is used, conserved, and re-used in the future is central to our work. Our products and services move, treat, analyze, monitor and return water to the environment, in public utility, industrial, residential and commercial building services settings. Xylem also provides a leading portfolio of smart metering, network technologies and advanced analytics solutions for water, electric and gas utilities. In more than 150 countries, we have strong, long-standing relationships with customers who know us for our powerful combination of leading product brands and applications expertise with a strong focus on developing comprehensive, sustainable solutions.

For more information on how Xylem can help you, go to www.xylem.com.



Service and Returns:

Xylem Analytics Germany
Sales GmbH & Co. KG
WTW
Am Achalaich 11
82362 Weilheim
Germany

Tel.: +49 881 183-325
Fax: +49 881 183-414
E-Mail wtw.rma@xylem.com
Internet: www.xylemanalytics.com



Xylem Analytics Germany GmbH
Am Achalaich 11
82362 Weilheim
Germany

